



S-015 S-016



Automatic Air Release Valve for High-Pressure Systems

Description

The automatic air release valve discharges accumulated air from the system while it is under pressure.

The presence of air in a water system can reduce the effective cross sectional flow area resulting in increased pressure loss and decreased flow.

Unwanted air may also cause water hammer and metering inaccuracies, while hastening corrosion.

Operation

The automatic air release valve, releases entrapped air from pressurized systems.

Without air valves pockets of accumulated air may cause the following destructive phenomena:

- Obstruction to effective flow and hydraulic conductivity of the system along with a throttling effect similar to a partially closed valve. In extreme cases this will cause complete flow stoppage.
- Accelerate cavitation damages.
- High-pressure surges.
- Accelerate corrosion.
- Danger of a high-energy burst of compressed air.

The valve functions while the system is under pressure, according to the following stages:

1. Liquid fills the system and enters the valve.
2. The float rises and rolls the rubber sealing band to its sealing position.
3. Entrapped air, which accumulates at peaks along the system, rises to the top of the valve, which in turn displaces the liquid in the valve's body.
4. The float descends, peeling the rolling seal, the orifice opens, and the accumulated air is released.
5. Liquid re-enters the valve and the float rises, rolling the rubber sealing band to its sealing position.

Note: Automatic air release valves are designed to release air as it accumulates at peaks of pressurized systems. They are not normally recommended for vacuum protection to release large volumes of air, because of the inherently small orifices. For this purpose air & vacuum air valves have much larger orifices. However, automatic air release valves will permit air to re-enter under vacuum conditions. If this is not desirable, specify vacuum check valves.

Main Features

- Working pressure range: 3-928 psi.
- Test pressure for the air valve is 1.5 times its working pressure.
- Working Temperature: 140° f.
- Maximum working temperature for short time period: 194° f.
- A.R.I. patent, rolling seal mechanism:
 1. Dramatically reduces the possibility of obstruction by debris.
 2. Discharges high air flow rates upto 452 CFM.
 3. One size orifice for a wide pressure range up to 928 psi.
 4. Self cleaning mechanism.
- Lightweight, small dimensions, simple and reliable structure.
- Standard metal body - baked FBE coating.
- All operating parts are made of specially selected corrosion resistant materials.

Valve Selection

- Available in 3/4", 1", male threaded NPT / flanged.
- S-015 Working pressure: 3-580 psi.
- S-016 Working pressure: 3-928 psi.

Ordering

Upon ordering, please specify: model, size, working pressure, threads standard and type of liquid.

AUTOMATIC AIR RELEASE

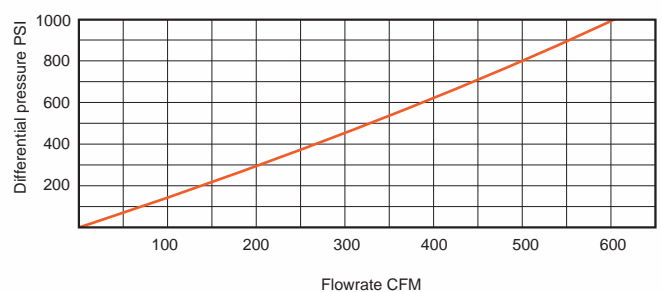

PARTS LIST AND SPECIFICATION FOR S-016

| No. | Part | Material |
|-----|---------------|--|
| 1. | Plastic Cover | Polypropylene |
| 2. | Washer | Stainless Steel SAE 316 |
| 3. | O-Ring | BUNA-N |
| 4. | Cover | Cast Steel ASTM A216 WCB |
| 5. | Nozzle | Nylon |
| 6. | Rolling Seal | Rubber E.P.D.M |
| 7. | O-Ring | BUNA-N |
| 8. | Bolt and Nut | Steel Zinc Cobalt Plated |
| 9. | Lever Seal | Nylon |
| 10. | Pin | Stainless Steel SAE 303 |
| 11. | Float | Polycarbonate / Stainless Steel SAE 316L |
| 12. | Body | Cast Steel ASTM A216 WCB |
| 13. | Male Adaptor | Stainless Steel SAE 316 |

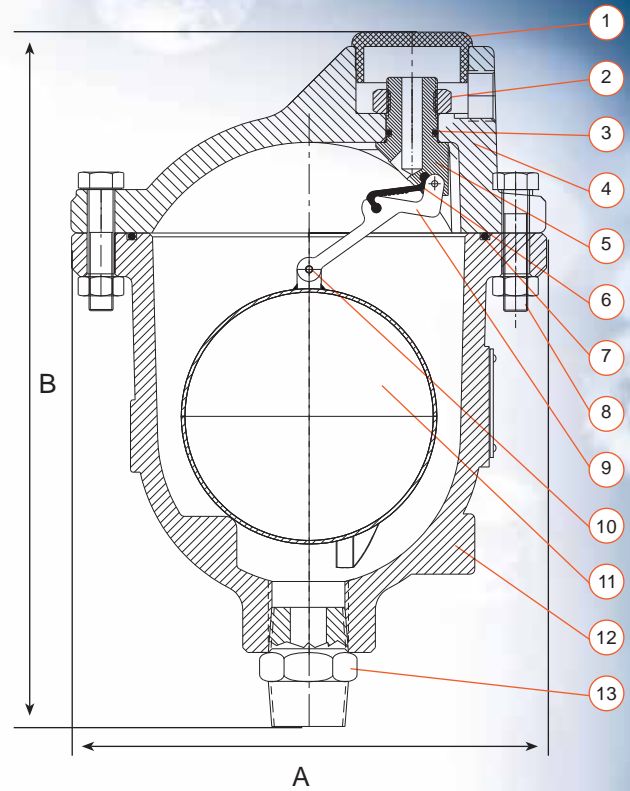

DIMENSIONS AND WEIGHT

| Nominal Size | Dimension | | | | Weight Lbs | Orifice Area Sq.in |
|--------------|-----------|-------|------------|----------|------------|--------------------|
| | A | B | internal C | external | | |
| S-015 | 6.22 | 11.49 | 0.8 | 1.1 | 11.9 | 0.0235 |
| S-016 | 7.75 | 11.6 | - | - | 28.6 | 0.0232 |

PARTS LIST AND SPECIFICATION S-015

| No. | Part | Material |
|-----|--------------------|---------------------------------|
| 1. | Discharge outlet | PVC |
| 2. | Rollpin | Stainless Steel SAE 304 |
| 3. | O-RING | BUNA-N |
| 4. | Nozzle | Reinforced Nylon |
| 5. | Cover | Ductile Iron ASTM A536 60-40-18 |
| 6. | Rollpin | Stainless Steel SAE 304 |
| 7. | Rolling Seal | E.P.D.M. |
| 8. | Lever Rolling Seal | Reinforced Nylon |
| 9. | Rollpin | Stainless Steel SAE 304 |
| 10. | O-RING | BUNA-N |
| 11. | Bolt, Nut & Washer | Steel, Zinc Cobalt Coated |
| 12. | Float | Polycarbonate |
| 13. | Body | Ductile Iron ASTM A536 60-40-18 |
| 14. | Adaptor | Brass |

