



D-040 250 PSI



Combination Air Valve

Description

The D-040 series Combination Air Valve has the features of both an air release valve and an air & vacuum valve.

The air release component is designed to automatically release small pockets of air to the atmosphere as they accumulate along a pipeline or piping system when it is full and operating under pressure.

The air & vacuum component is designed to automatically discharge or admit large volumes of air during the filling or draining of a pipeline or piping system. This valve will open to relieve negative pressures whenever water column separation occurs.

Applications

- Pump stations: after the pump and after the check valve
- Downstream (after) and upstream (before) of shut-off valves
- After deep-well pumps
- On long constant-sloped pipeline segments
- At peaks along the pipeline and at peaks relative to hydraulic gradient.
- At end lines
- Before water meters
- On strainers and filters

D-040-C - additional applications

- Water pipelines vulnerable to vandalism and/or water theft.
- Water systems found in remote areas.

Operation

The air & vacuum component, with the large orifice, discharges air at high flow rates during the filling of the system and admits air into the system at high flow rates during its drainage and at water column separation.

High velocity air should not blow the float shut. Water will lift the float, which seals the valve.

At any time during system operation, should internal pressure of the system fall below atmospheric pressure, air will re-enter the system.

The smooth discharge of air reduces pressure surges and other destructive phenomena.

The intake of air in response to negative pressure protects the system from destructive vacuum conditions and prevents damage caused by water column separation. Air re-entry is essential to efficiently drain the system.

The air release component releases entrapped air in pressurized systems.

Without air valves, pockets of accumulated air may cause the following destructive phenomena:

- Obstruction of effective flow and hydraulic conductivity of the system along with a throttling effect as would a partially closed valve. In extreme cases this will cause complete flow stoppage.
- Acceleration of cavitation damages
- High-pressure surges.
- Acceleration of corrosion to metal parts.
- Danger of a high-energy burst of compressed air.
- Inaccuracies in flow metering.

As the system starts to fill, the valve functions according to the following stages:

1. Entrapped air in the pipeline is discharged by the valve.
2. Liquid enters the valve, lifting the float which pushes the sealing mechanism to its sealing position.
3. Entrapped air, which accumulates at peaks along the system (where combination air valves should be installed), rises to the top of the valve, which in turn displaces the liquid in the valve's body.
4. The float descends, unsealing the rolling seal. The air release orifice opens and the accumulated air is released.
5. Liquid penetrates into the valve and the float rises, pushing the rolling seal back to its sealing position.

When internal pressure falls below atmospheric pressure (negative pressure):

1. The float will immediately drop down, opening the air & vacuum and air release orifices.
2. Air will reenter the system.

Main Features

- Working pressure range: 3 - 250 psi.
- Testing pressure: 360 psi.
- Maximum working temperature: 140° F.
- Maximum intermittent temperature: 194° F.
- Reliable operation reduces water hammer incidents.
- Dynamic design allows for high velocity air discharge while preventing premature closure.
- Lightweight, small dimensions, simple and reliable structure.
- The drainage outlet enables removal of excess fluids.
- **The large size of the automatic air release orifice relative to the air valve body:**

- Discharges air at high flow rates.
- Lessens the danger of its obstruction by debris.
- Enables the usage of the patented rolling seal mechanism, making it less sensitive to pressure differential than a direct float seal.
- The body is made of high-strength composite materials and all operating parts are made of specially selected, corrosion-resistant materials.
- Due to its light weight, the valve may be installed on plastic piping systems, as well as other lightweight piping systems.
- D-040-C the body is protected in a metal shell for anti-vandalism/ theft applications



AUTOMATIC AIR RELEASE

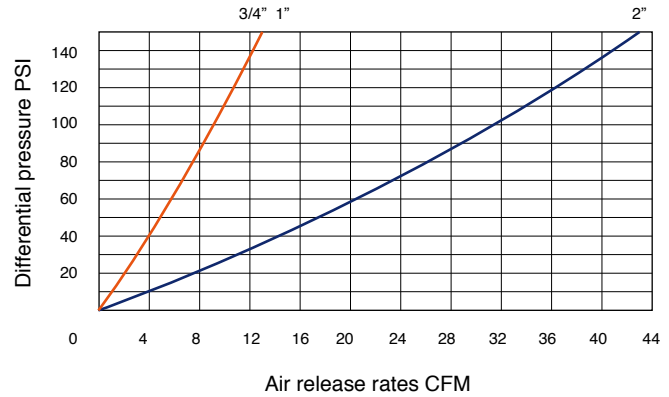

AIR AND VACUUM FLOW RATE

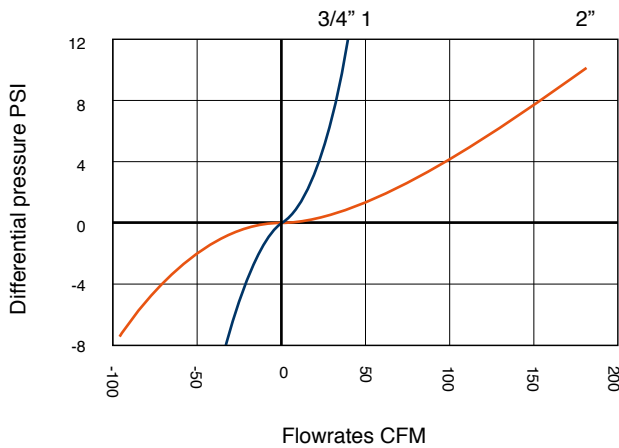

DIMENSIONS AND WEIGHT

Nominal Size	Dimensions inch				Weight Lbs.	Orifice Area Sq.in	
	A	B	internal	C external		Air & Vac.	Auto.
D-040 3/4" 1"	3.9	5.5	3/8 NPT	0.86	0.73	0.155	0.012
D-040 2"	7	8.2	1 1/2 NPT	2.16	2.35	1.246	0.018
D-040 NT 2"	5	8.2	1 1/2 NPT	2.16	2.2	1.246	0.018

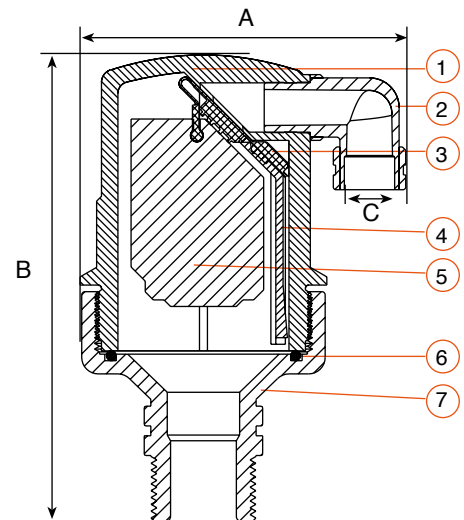

PARTS LIST AND SPECIFICATION

No. Part	Material
1. Body	NSF 61 Certified Reinforced Nylon
2. Discharge Outlet	NSF 61 Certified Polypropylene
3. 3/4" 1" Rolling Seal 2" Rolling Seal Assembly	NSF 61 Certified E.P.D.M.
3a. Screws	Stainless Steel
3b. Plug Cover	NSF 61 Certified Reinforced Nylon
3c. Rolling Seal	NSF 61 Certified E.P.D.M.
3d. Plug	NSF 61 Certified Reinforced Nylon
4. Clamping Stem	NSF 61 Certified Reinforced Nylon
5. Float	NSF 61 Certified Foamed Polypropylene
6. O - Ring	NSF 61 Certified NBR 70
7. Base	NSF 61 Certified Reinforced Nylon

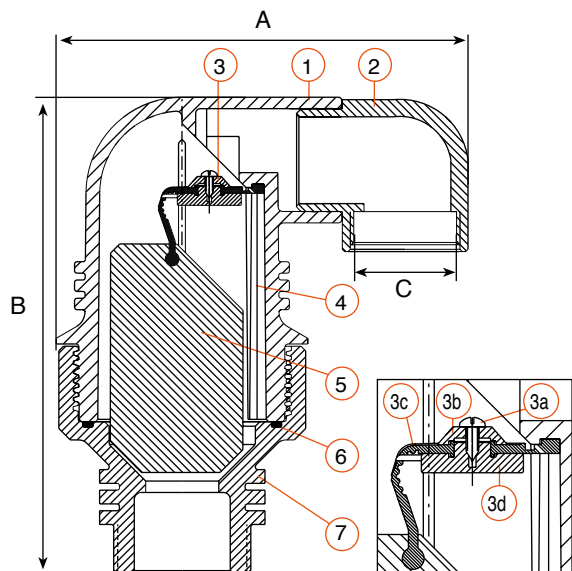

AIR AND VACUUM FLOW RATE

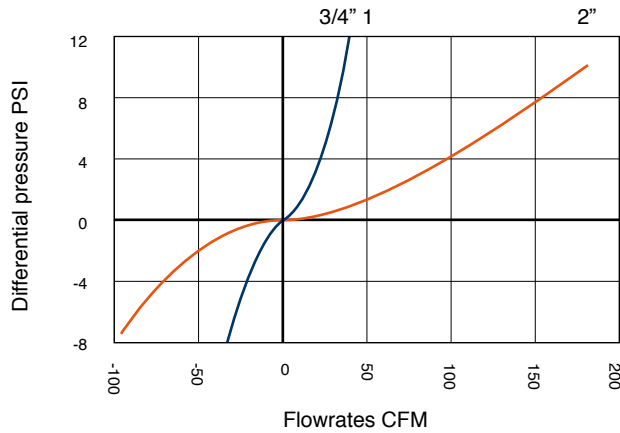

AUTOMATIC AIR RELEASE

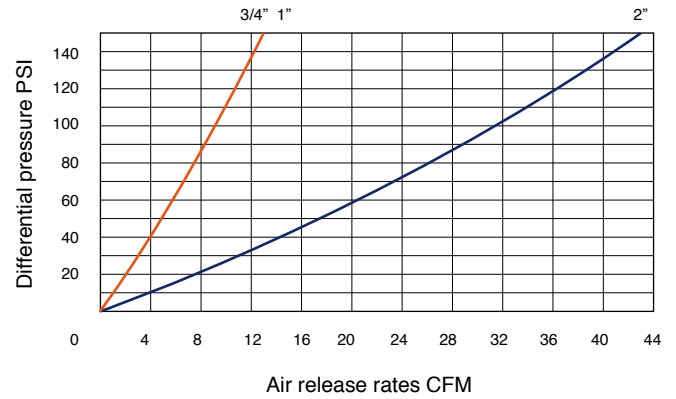

D-040-C



D-040-STST



D-040-C 3/4" 1"

DIMENSIONS AND WEIGHT

Nominal Size	Dimensions inch				Weight Lbs.	Orifice Area Sq.in	
	A	B	internal C	external		Air & Vac.	Auto.
D-040-C 1"	4.7	5.9	3/8 NPT	0.86	3.75	0.127	0.0077
D-040-C 2"	8	9	1 1/2 NPT	2.16	11.9	1.246	0.0186
D-040 STST 2"	7.0	8.2	1 1/2 NPT	2.16	8.96	1.246	0.0186

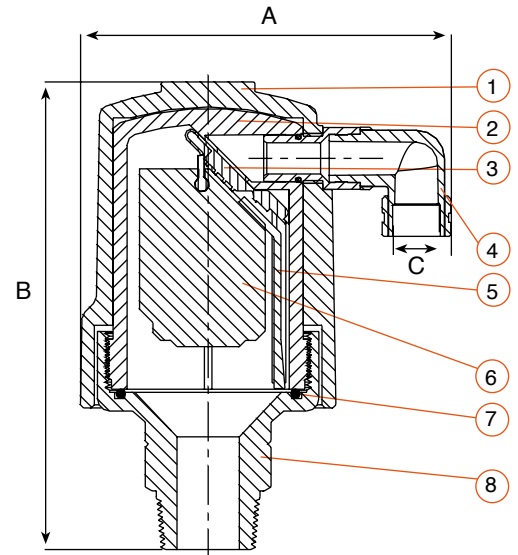

PARTS LIST AND SPECIFICATION

No. Part	Material
1. Shell	Cast Iron ASTM A48 CL.35B
2. Body	NSF 61 Certified Reinforced Nylon
3. 3/4" 1" Rolling Seal 2" Rolling Seal Assembly	NSF 61 Certified E.P.D.M.
3a. Screws	Stainless Steel
3b. Plug Cover	NSF 61 Certified Reinforced Nylon
3c. Rolling Seal	NSF 61 Certified E.P.D.M.
3d. Plug	NSF 61 Certified Reinforced Nylon
4. Discharge Outlet	NSF 61 Certified Polypropylene
5. Clamping Stem	NSF 61 Certified Reinforced Nylon
6. Float	NSF 61 Certified Foamed Polypropylene
7. O - Ring	NSF 61 Certified NBR 70
8. Base 3/4" 1"	Stainless Steel ASTM A744 CF8M (NSF)
2"	Cast Iron ASTM A48 CL.35B
9. Bolts & Nuts	Stainless Steel ASTM A744 CF8M (NSF)

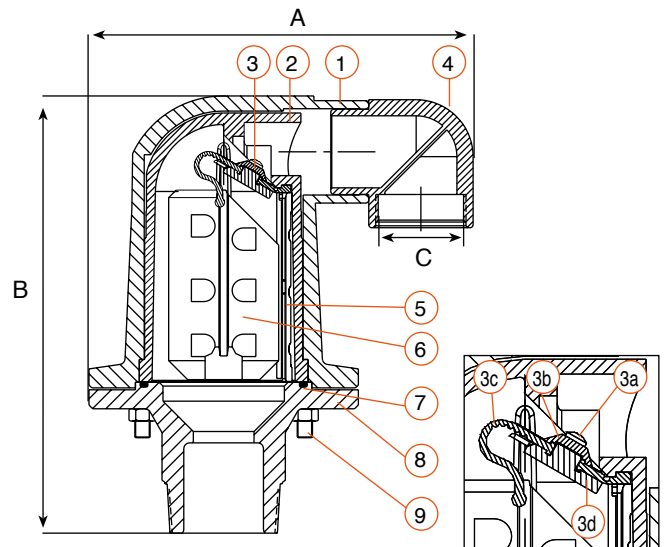

Valve Selection

The air valve is available with:

- Wide size range: 3/4", 1", 2" threaded male NPT connections.
- D-040 body made of composite materials.
- D-040-C the body is protected in a metal casting for anti-vandalism/theft applications
- D-040 STST body made of Stainless Steel.
- D-040 ST with Stainless Steel base.

ACCESSORIES

One-way models

The D-040 series air valve is available as:

- D040-V -With a vacuum guard, out-only attachment, allows air discharge only, prevents air intake (all models).
- D-040-I -With a vacuum breaker, in-only attachment, allows air intake only, not allowing air discharge (D-040 2" only).
- D-040-NS -With a non-slam, discharge-throttling attachment, allows full air intake, throttles air discharge (D-040 2" only).

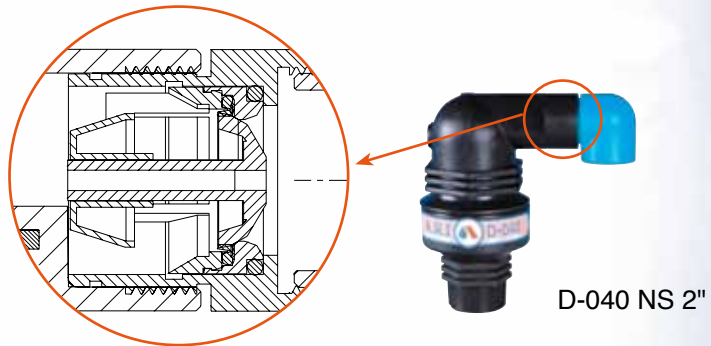

Screen

Prevents penetration of debris and insects and can be assembled on the valve before or after the Discharge outlet.
Each strainer has 2 threaded connections 1.5" NPSM/ 2" NPSM.



Air Valve Enclosure

A.R.I. air valve enclosure is used to protect air valve, for above surface air valve installations.
The special enclosure protects and hides the air valves from vandalism and damages.

