



# D-090-P

250 PSI



## UNDERGROUND AIR VALVE SYSTEM

### Description

Save manhole costs with the new A.R.I. UNDERGROUND AIR VALVE SYSTEM, designed to provide reliable solutions for special needs such as:

- Better frost protection.
- Savings in installation costs.
- Installations under important crossings: roads, pavements, buildings.

**Eliminates the safety considerations and extra costs associated with confined space entry.**

### Operation

The air & vacuum component, with the large orifice, discharges air at high flow rates during the filling of the system and admits air into the system at high flow rates during its drainage and at water column separation.

High velocity air should not blow the float shut. Water will lift the float which seals the valve.

At any time during system operation, should internal pressure of the system fall below atmospheric pressure, air will re-enter the system.

The smooth discharge of air reduces pressure surges and other destructive phenomena.

The intake of air in response to negative pressure protects the system from destructive vacuum conditions and prevents damage caused by water column separation. Air re-entry is essential to efficiently drain the system.

The automatic small orifice air release component releases entrapped air in pressurized systems.

**Without air valves, pockets of accumulated air may cause the following destructive phenomena:**

- Obstruction of effective flow and hydraulic conductivity of the system along with a throttling effect similar to a partially closed valve. In extreme cases this will cause complete flow stoppage.
- Accelerate cavitation damages.
- High-pressure surges.
- Accelerate corrosion.
- Danger of a high-energy burst of compressed air.
- Inaccuracies in flow metering.

**As the system starts to fill, the valve functions according to the following stages:**

1. Entrapped air in the pipeline is discharged by the valve.

2. Liquid enters the valve, lifting the float which pushes the sealing mechanism to its sealing position.

3. Entrapped air, which accumulates at peaks along the system (where combination air valves should be installed), rises to the top of the valve, which in turn displaces the liquid in the valve's body.

4. The float descends, unsealing the rolling seal. The air release orifice opens and the accumulated air is released.

5. Liquid penetrates into the valve and the float rises, pushing the rolling seal back to its sealing position.

**When internal pressure falls below atmospheric pressure (negative pressure):**

1. The float will immediately drop down, opening the air & vacuum and air release orifices
2. Air will reenter the system.

### Main Features

- Working range: 2-150 psi, 3 - 250 psi.
- Maximum working temperature: 140° F.
- Maximum intermittent temperature: 194° F.
- Materials: the air valve is made of corrosion-resistant materials.
- Integral shut-off valve: shuts off automatically when removing the air valve for maintenance purposes.
- Drainage System: A special one-way outlet drains the water from the valve box and prevents water intake.
- Dynamic design allows high velocity air discharge, prevents premature closing.
- **A.R.I. patented rolling Seal Mechanism:**
  - Dramatically reduces obstruction by debris.
  - The automatic function discharges high air flow rates.
  - Self - cleaning mechanism.
  - Low maintenance costs.
- Air valve box made of P.V.C. – according to high-quality standard.
- Light weight and compact silhouette.

### Valve Selection

- Connection: threaded 2", flanged 2", 3", 4" to meet ASA 150 standard or any requested standard.
- Eight different installation lengths: 1½, 3, 4, 5, 6, 7, 8 Ft.

## The Old Concept Requires High Costs

- Digging (Excavating).
- Large manhole.
- Sealing materials and labor.
- Separate shut-off valve.

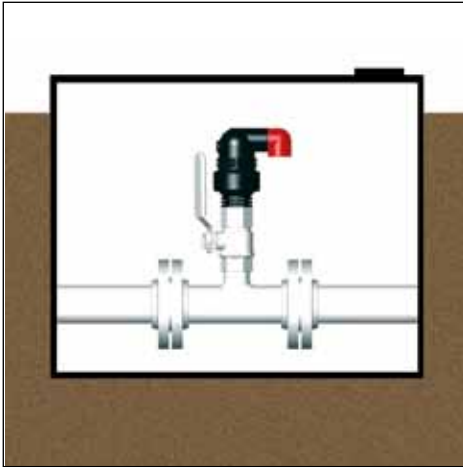

## Installation

Two installation possibilities:

### Stand post installation

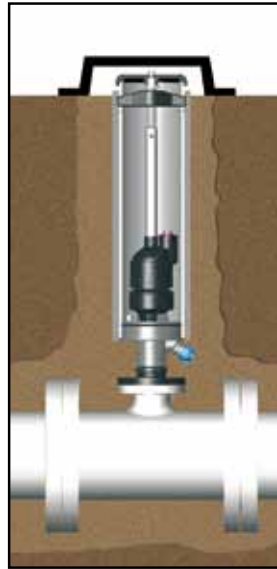

### Under ground installation with street cap

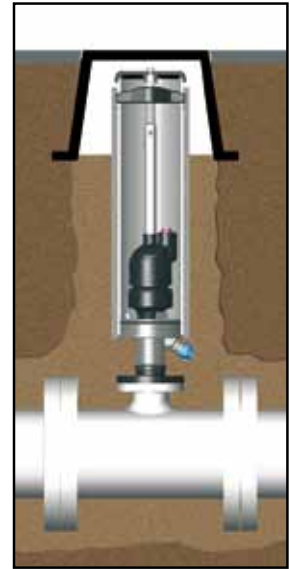

## The new approach saves costs in means of

- Manhole - is not needed
- Innovative air valve.
- Sealing the manhole - is not needed.
- Automatic shut-off valve - included.



## AIR AND VACUUM FLOWRATE

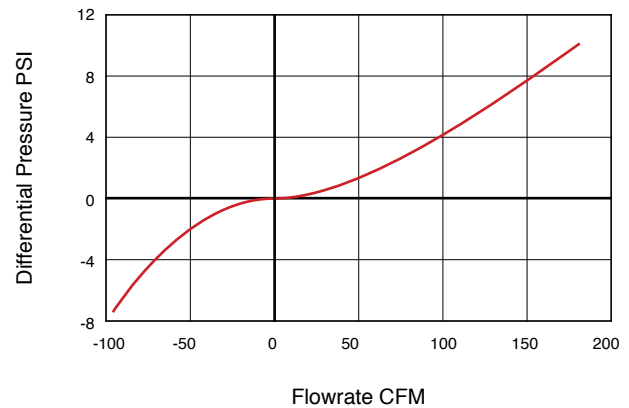

## AUTOMATIC AIR RELEASE

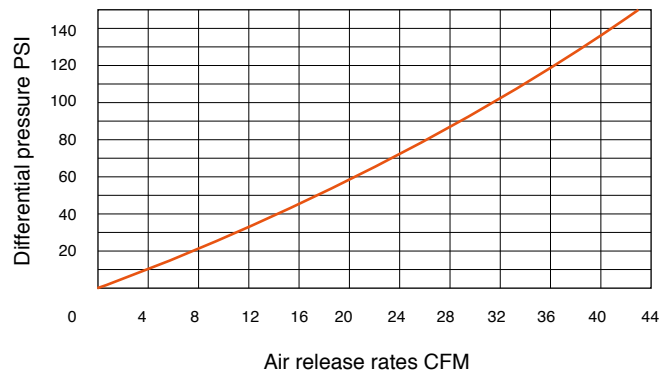

## DIMENSIONS AND WEIGHT

Dim. Inch		Weight Lbs.	
W	H	Aluminium Base	Sphero Base
7.7	18.0	12.8	15.4
7.7	36.0	16.0	18.7
7.7	48.0	19.6	21.6
7.7	60.0	24.5	27.1
7.7	72.0	27.3	30.0
7.7	84.0	30.2	32.8
7.7	96.0	33.0	35.9

## PARTS LIST AND SPECIFICATION

No. Part	Material
1 Base	Ductile Iron / Aluminum
2 Cover	Aluminum
3 Bridge	Reinforced Nylon
4 Bridge Bolt	Reinforced Nylon
5 Tightening Rod	Stainless Steel SAE 304
6 Air Valve Box	P.V.C
7 D-040 base	Reinforced Nylon
8 D-040 body	Reinforced Nylon
9 D-040 cover	Reinforced Nylon
10 Activating Lug	Reinforced Nylon
11 Lock pin	Stainless Steel SAE 304
12 Bolt housing	Stainless Steel SAE 316
13 Stopper	Aluminum
14 Rolling Seal Assembly	STST + RN + E.P.D.M.
15 Adaptor	Stainless Steel
16 Clamping Stem	Reinforced Nylon
17 Float	Foamed Polypropelene
18 Drainage Outlet	PE
19 Check Valve	Acetal/ Rubber/St.St.
20 Check Valve (D-090-P V)*	Acetal/ Rubber/St.St.
21 Check Valve	Acetal/ Rubber/St.St.
22 O-Ring	BUNA-N
23 O-Ring (D-090-P V)*	BUNA-N
24/25O-Ring	BUNA-N
26/27/28Bolt	Stainless Steel SAE 316
29 Self-Locking Nut	Stainless Steel SAE 316
30 Bolt	Stainless Steel SAE 316
31/32Washer	Stainless Steel SAE 316
33 Spring Washer	Stainless Steel SAE 316
34 Insulation	Aluminum-coated Foamed PE

\* Option -upon request

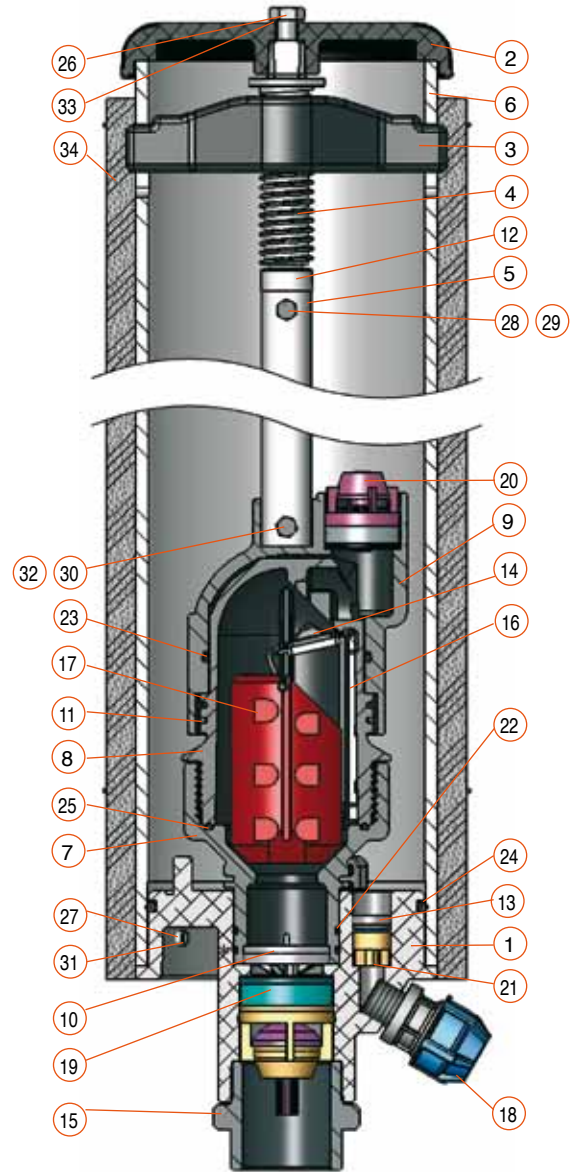

## Option

- One-way addition for discharge of air only, not allowing for air intake.
- "Non-Slam" discharge-throttling attachment, allows full air intake, throttles air discharge.
- D-090-P for corrosive fluids.
- D-090-P U: approved for NSF 61
- D-090-P LP: for low pressure

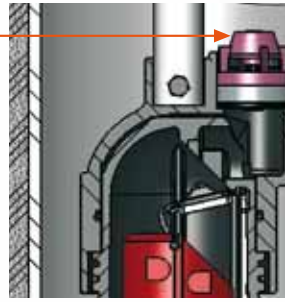

- **Service Tap:** Extracting water from the line (Sampling, cleaning purposes etc).  
Cleaning of the line itself.
- Releasing large quantities of air from the line  
Manually.

Internal frost protection.



## Maintenance Advantages – Cost Saving

- Maintenance of the valve requires only one maintenance worker.
- The maintenance work can be performed when the system is under pressure.
- The maintenance can be done at the site.
- Assembly of the air valve is the same as dismantling, only in reverse order.

1)

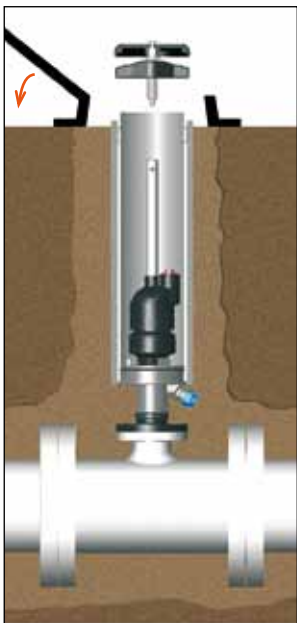

Turn the cover counterclockwise, release and remove the cover, bridge and bolt assembly as one unit.

2)

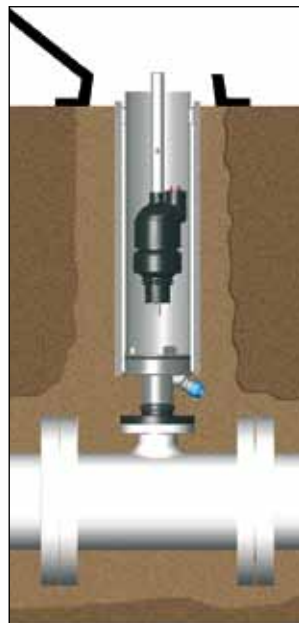

Remove the valve assembly by grasping the rod and lifting the assembly upwards.

## Combination air valve "Barak" model D-040 maintenance instruction

### General instructions

1. Routine service is an integral part of the standard procedure for maintenance of a water supply system.
2. Recommended routine maintenance— once or twice a year, depending on the water quality in the system.

### Procedure

1. Turn , release and remove the valve cover (1).
2. Release and separate the valve body (5) from the base (6).
3. Take out the lock pin (4)
4. Check the perfection of the seal plug assembly (2) and wash it with water. Replace the seal assembly in case it is torn.
5. Check and wash the internal body (5) and the float (3) with clean water.
6. Clean the drainage outlet of the cover (1) and remove insects and debris.
7. While you are reassembling the air valve system, be sure that the O-rings are placed in their places properly.

